

OMNIA + LEVEL Smart Deadbolt Entrance Handleset (Stainless Steel)

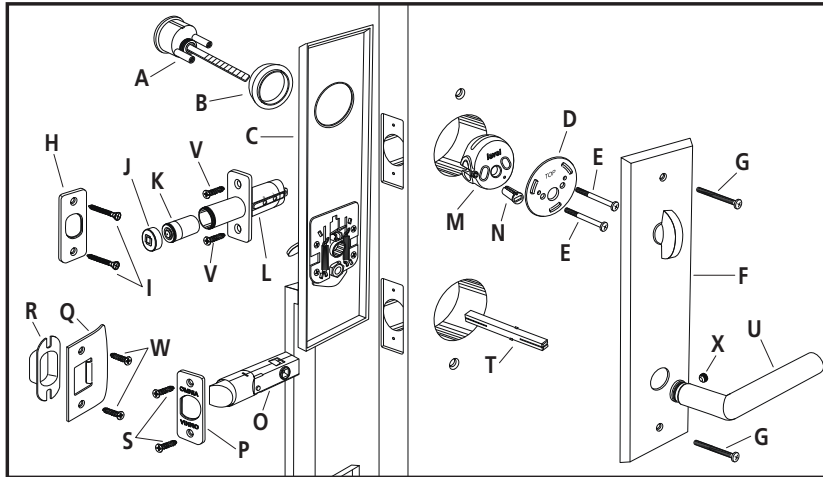

Instructions/Template for Single Cylinder



Parts Enclosed:

- | | |
|--|--|
| A - Tailpiece Cylinder with Studs | M - Level Deadbolt Housing |
| B - Cylinder Collar | N - Hub of Level Bolt |
| C - Exterior Plate with Thumbpiece | O - Tubular Latch |
| D - Mounting Plate for Cylinder | P - Tubular Latch Faceplate |
| E - 2 - 2" Cylinder Mounting Screws | Q - Tubular Latch Strike |
| F - Inside Backplate | R - Tubular Latch Dust Box |
| G - 2 - 1 3/4" Mounting Screws for Inside Backplate | S - 2 - 1" Mounting Screws for Tubular Latch Faceplate |
| H - Level Strike | T - Spindle (Tear drop groove positioned towards set screw) |
| I - 2 - 1 1/2" Mounting Screws for Level Strike | U - Lever |
| J - Level Battery Cap | V - 2 - 1" Mounting Screws for Level Deadbolt Faceplate |
| K - CR2 Battery | W - 2 - 1" Mounting Screws for Tubular Latch Strike |
| L - Level Deadbolt | X - Set Screw |

Tools Needed:

Doors Prepared with 2 1/8" Cutout

- 1 - No.1 and No.2 Phillips screwdrivers
- 2 - Measuring device
- 3 - Flathead screwdriver
- 4 - Pliers or hacksaw
- 5 - Metal file

800-310-7960 / www.OMNIAindustries.com

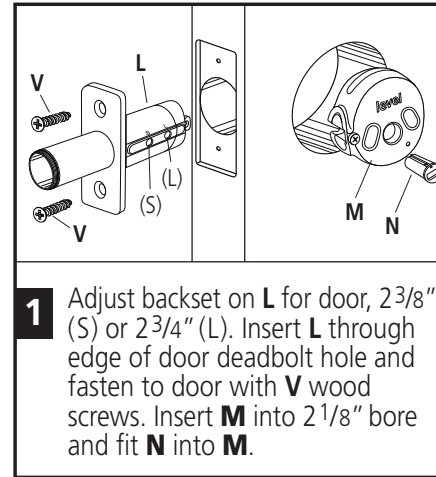

1 Adjust backset on **L** for door, 2 3/8" (S) or 2 3/4" (L). Insert **L** through edge of door deadbolt hole and fasten to door with **V** wood screws. Insert **M** into 2 1/8" bore and fit **N** into **M**.

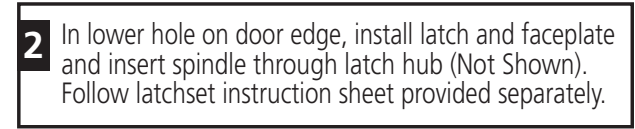

2 In lower hole on door edge, install latch and faceplate and insert spindle through latch hub (Not Shown). Follow latchset instruction sheet provided separately.

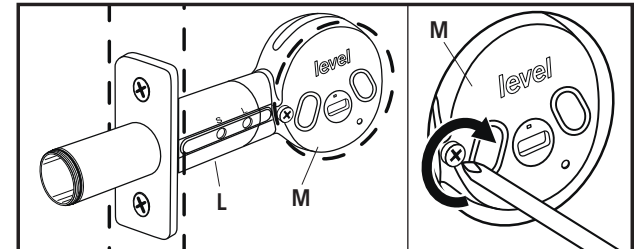

3 While **M** is inside of 2 1/8" bore, attach **L** to **M** using screw already assembled to body of **M**.

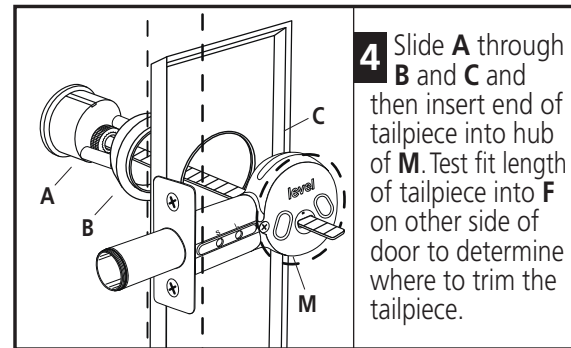

4 Slide **A** through **B** and **C** and then insert end of tailpiece into hub of **M**. Test fit length of tailpiece into **F** on other side of door to determine where to trim the tailpiece.

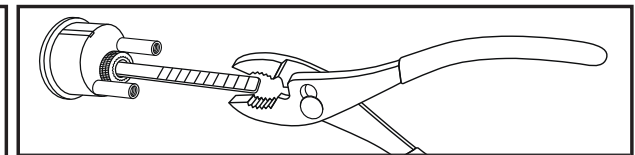

5 Trim the appropriate amount of length from tailpiece using either a hacksaw or break with a pair of pliers. The tailpiece may need to be filed down to assure proper movement of the Level bolt when used electronically. (May work manually, but not electronically. Tailpiece may be too long.) Remove studs on cylinder, if required.

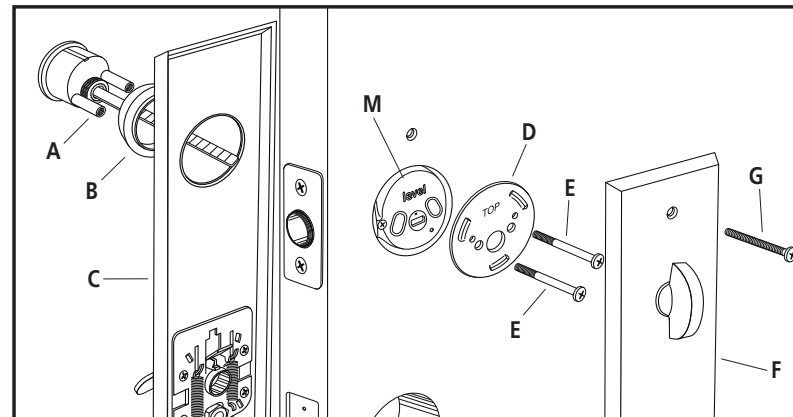

6 Slide **A** through **B** and **C** and then slide tailpiece through hub of **M** and large hole of **D**. From interior side, insert the two **E** screws through **D** and **M** and tighten into **A**. Attach **F** so that the tailpiece slides into the turnpiece and the spindle below slides into the lever attached to the backplate. Fasten at both ends of backplate using **G** screws. On interior side of door, secure lever with set screw **X**.

OMNIA level

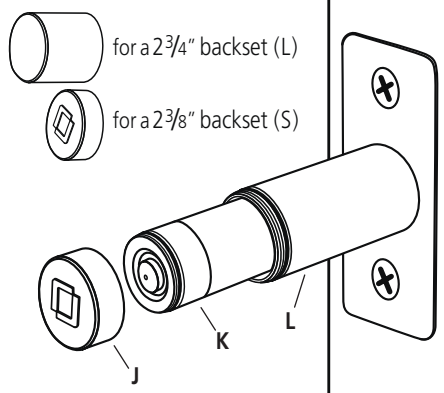

for a 2 $\frac{3}{4}$ " backset (L)
for a 2 $\frac{3}{8}$ " backset (S)

7 Insert battery **K** into deadbolt **L** and thread the correct **J** cover for backset onto deadbolt.

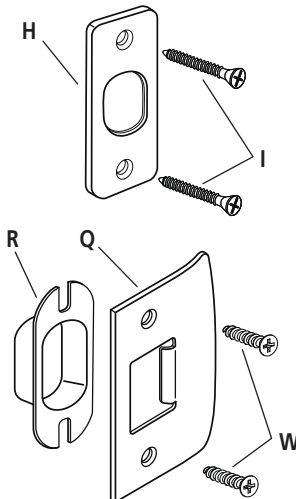

8 In the upper hole of door frame, attach **H** with **I** screws and in the lower hole, insert **R** and then secure **Q** over that with **W** screws.



Testing Test proper orientation of deadbolt, electronically. First test the operation with the door in the open position, and then test the deadbolt in the closed position. When closed, always test from the inside of the door (in order to prevent getting locked out).

Congratulations - Your installation is now complete! If you have any trouble, please call OMNIA at the number listed below. We thank you for your purchase.

