

INSTALLATION TEMPLATE FOR OMNIA 4.5" HINGES

NOTE: Template may not be true-to-size.
Please use for reference purposes only.
Do NOT drill until measurements are verified.

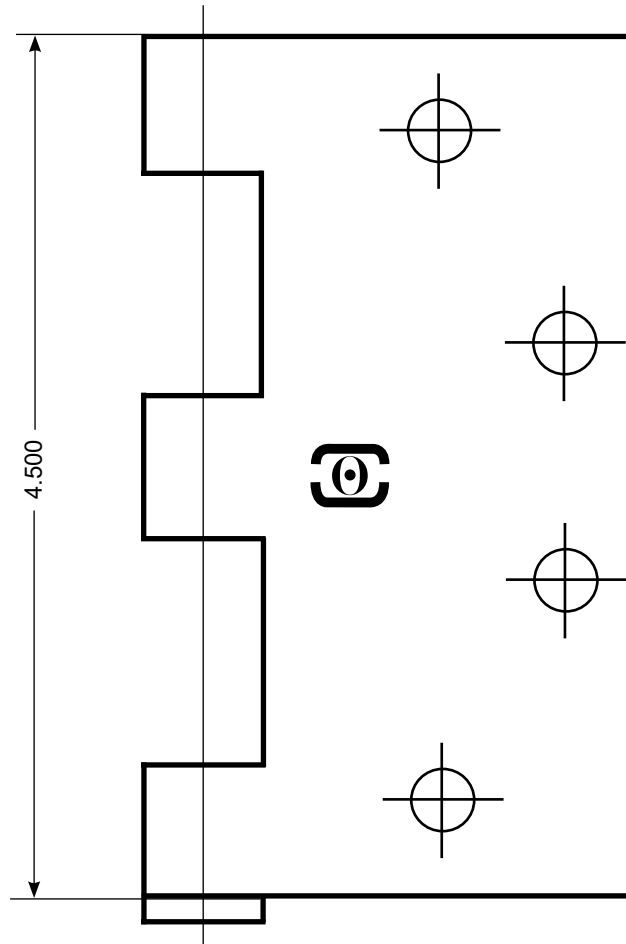

985BB/45 & 985/45

OMNIA

985/45 & 985BB/45

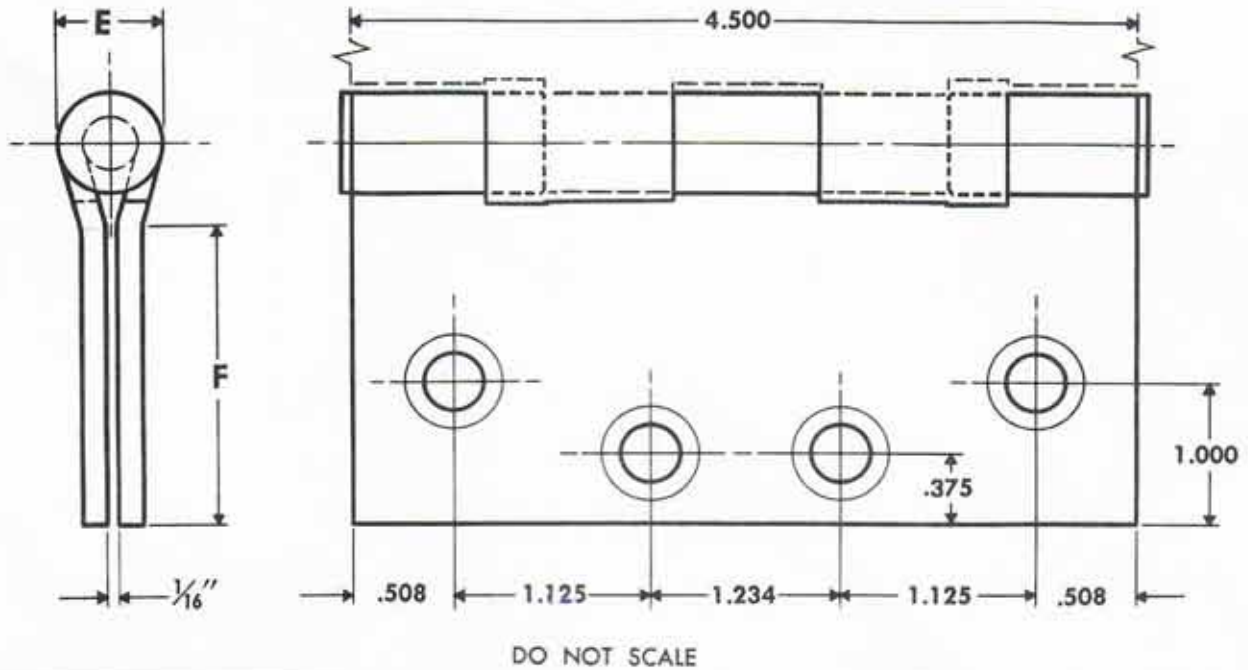

Gauge of Metal	(E) Outside Diameter	(F) Distance from Edge of Leaf to Swage Line
.134	.625	1-25/32"

Machine Screw Size — $1/2 \times 12-24$ F.H.
Wood Screw Size — $1/4 \times$ No. 12 F.H.