



OMNIA INDUSTRIES, INC.

CEDAR GROVE, NJ 07009



TO REVERSE 2½" OR 2¾" B.S. MORTISE LEVER x LEVER/KNOB x KNOB LOCK BODY

To Reverse Lever x Lever Lock Body

1. Place lock body flat on work surface with the latch bolt pointing to the left and the cylinder hole to the top of the lock, as shown in the diagram.
2. **INSERT AND TIGHTEN THE PROVIDED 8-32 x 5/8" FLAT HEAD SCREW INTO THE SCREW HOLE AS MARKED ON THE DIAGRAM.**
3. Flip lock over and remove screws holding lock cover on and remove lock cover.
4. Remove the cylinder latch lever and stop lever that goes over the latch bolt rod and spring.
5. Take note to the direction of the latch bolt bevel. Remove the latch bolt by lifting the square stop at the back of the latch bolt rod, and slide out the latch bolt.
6. Rotate the latch bolt over so that the bevel is opposite of the original bevel and install the latch bolt back into the lock case.
7. Take note to which side of the lock has the locking spindle hub. Remove both spindle hubs and reverse the side of the lock the locking spindle hub is positioned.
8. Replace the cylinder latch lever and stop lever that go over the latch bolt rod.
9. Replace the case cover and tighten screws.
10. **REMOVE THE 8-32 X 5/8" SCREW FROM STEP 2.**

Reversing is now complete.

To Reverse Knob x Knob Lock Body

Follow above instructions starting with Step 3.

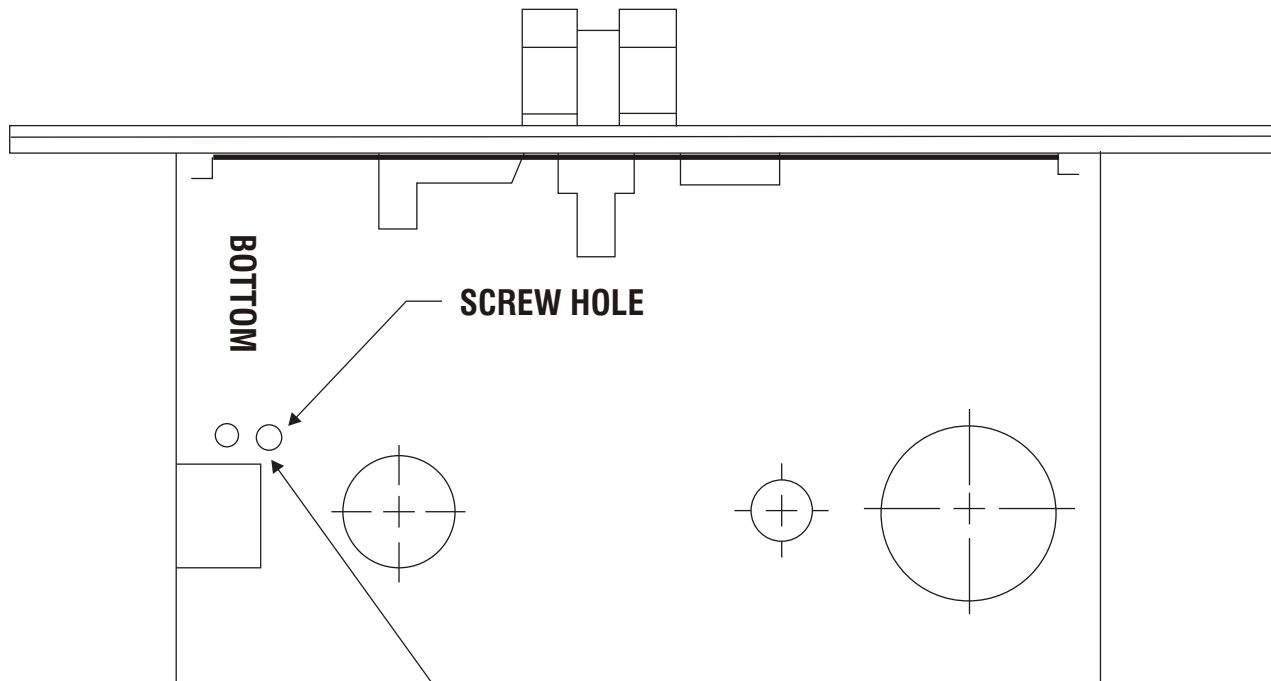

**BEFORE REMOVING COVER
INSERT AND TIGHTEN
8-32 x 5/8" FLAT HEAD SCREWS
INTO HOLE IN BOTTOM OF CASE. (SHOWN ABOVE)**

OMNIA

Ph. 800.310.7960
www.OmniaIndustries.com

OM-212/234MLACRI
Rev. 4/20/2015