



## 2-1/2" OR 2-3/4" BACKSET MORTISE HANDLE SET LOCKBODY

### To Reverse Lever x Handle Set Lock Body

1. Place lock body flat on work surface with the latch bolt pointing to the left and the cylinder hole to the top of the lock, as shown in the diagram.
2. **INSERT AND TIGHTEN THE PROVIDED 8-32 x 5/8" FLAT HEAD SCREW INTO THE SCREW HOLE AS MARKED ON THE DIAGRAM.**
3. Flip lock over and remove screws holding lock cover on and remove lock cover.
4. Reverse ***latch bolt only***. (Lock spindle hubs do not need to be reversed.)
5. Replace lock case cover and tighten screws.
6. Remove the 8-32 x 5/8" screw from step 2.

***Reversing is now complete.***

### To Reverse Knob x Handle Set Lock Body

Follow above instructions starting with Step 3.

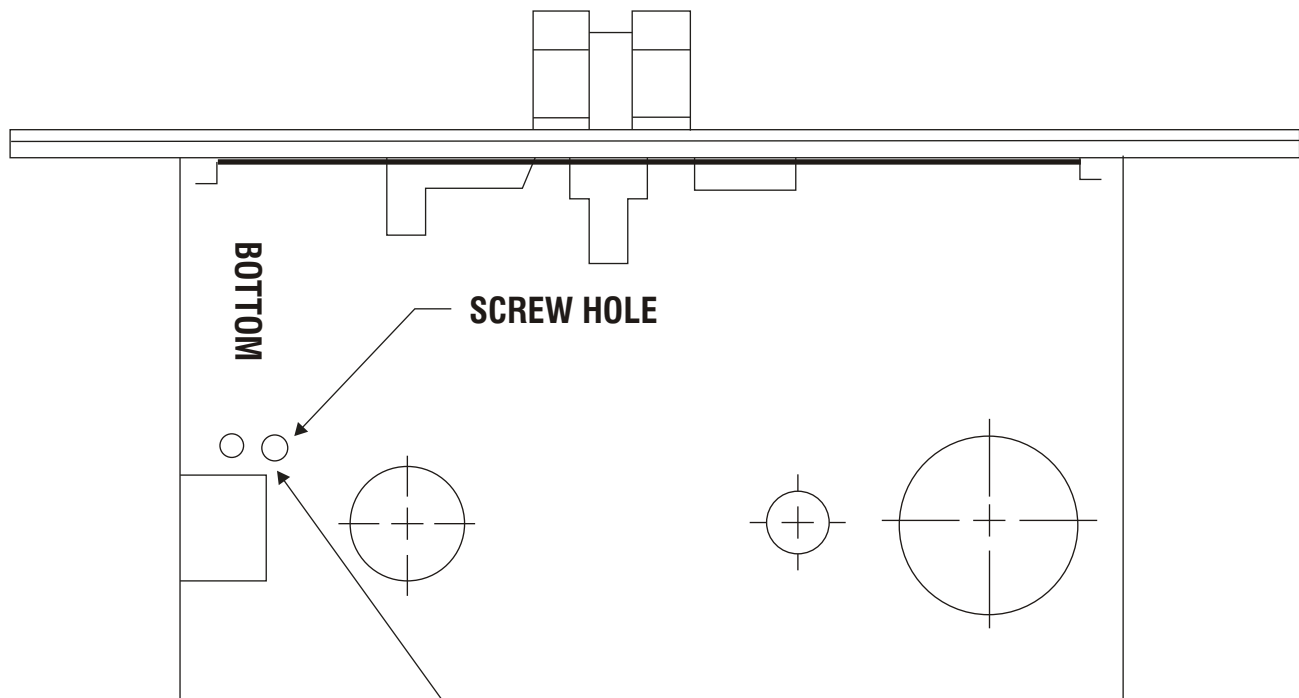

**BEFORE REMOVING COVER  
INSERT AND TIGHTEN  
8-32 x 5/8" FLAT HEAD SCREW  
INTO HOLE IN BOTTOM OF CASE. (SHOWN ABOVE)**